

SDP600 Series (SDP600/610/500/510) Low-cost Digital Differential Pressure Sensor

- Accuracy better than 0.2% FS near zero
- Digital output (I²C)
- Excellent repeatability, even below 10 Pa
- Calibrated and temperature compensated
- Excellent long-term stability



Product Summary

The SDP600 sensor family is Sensirion's series of digital differential pressure sensors designed for high-volume applications. They measure the pressure of air and non-aggressive gases with superb accuracy and no offset drift. The sensors cover a pressure range of up to ± 500 Pa (± 2 inch H₂O / ± 5 mbar) and deliver outstanding accuracy even at the bottom end of the measuring range.

The SDP600 operates from a 3.3 Vdc supply voltage and features a digital 2-wire interface, which makes it easy to connect directly to a microprocessor. The signal is internally linearized and temperature compensated.

The outstanding performance of these sensors is based on Sensirion's patented CMOSens[®] sensor technology, which combines the sensor element, signal processing and digital calibration on a tiny microchip. The differential pressure is measured by a thermal sensor element using flow-through technology. Compared with membrane-based sensors, the SDP600 features an extended dynamic range, better long-term stability, and improved repeatability, especially near zero.

The well-proven CMOS technology is perfectly suited for high-quality mass production and is the ideal choice for demanding and cost-sensitive OEM applications.

Applications

- Medical (e.g. respiratory devices)
- HVAC
- Automotive
- Process automation

Connection diagram

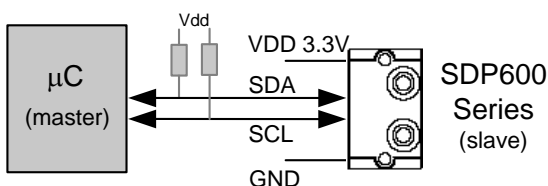

SDP600 series with bidirectional digital communication (I²C bus)

Sensor chip

The SDP600 series features a fourth-generation silicon sensor chip called SF04. In addition to a thermal mass flow sensor element, the chip contains an amplifier, A/D converter, EEPROM memory, digital signal processing circuitry, and interface. The highly sensitive chip requires only a minuscule amount of gas flow through the sensor.

Evaluation kit

The *EK-P2* evaluation kit is available for sensor evaluation and qualification. The EK-P2 kit includes 3 sensors plus support hardware and software for interfacing with a PC.

OEM options

A variety of custom options can be implemented for high-volume OEM applications. Ask us for more information.

1. Sensor Performance

1.1 Physical specifications¹

Parameter	SDP600/SDP610	SDP500/SDP510
Measurement range	- 500 to + 500 Pa (- 2.0 to + 2.0 in. H ₂ O)	
Calibrated range	- 500 to + 500 Pa (± 2.0 in. H ₂ O)	0 to + 500 Pa ² (0 to + 2.0 in. H ₂ O)
Resolution	12 bits preset (for 9–16 bits see documentation)	
Zero point accuracy ^{3,4}	0.2 Pa	
Span accuracy ^{3,4}	3% of reading	4.5% of reading
Zero point repeatability ³	0.1 Pa	
Span repeatability ³	0.5% of reading	
Offset shift due to temperature variation	None (less than resolution)	
Span shift due to temperature variation	< 0.5% of reading per 10°C	
Offset stability	< 0.1 Pa/year	
Response time	4.6 ms typical with 12-bit resolution (See documentation for response times with other resolutions, e.g. 1.3 ms with 10 bits)	
Warm-up time for first reliable measurement	50 ms (first measurement after 16 ms)	

¹ Unless otherwise noted, all sensor specifications are at 23°C with V_{dd} = 3.3 Vdc and absolute pressure = 966 mbar.

² The SDP500/SDP510 sensors do measure in the full range from -500 to +500 Pa. But in contrast to the SDP600/SDP610 we do not guarantee the specified accuracy for the negative measurement range for SDP500/SDP510.

³ With 12-bit resolution; includes repeatability and hysteresis.

⁴ The zero-point accuracy and span accuracy are independent uncertainties and add according to the principles of error propagation.

1.2 Ambient conditions

Parameter	SDP600 Series
Media compatibility ⁵	Air, N ₂
Limited media compatibility ⁶	O ₂
Calibrated temperature range ⁵	0 °C to +50 °C
Operating temperature	-20 °C to +80 °C
Storage temperature ⁵	-40 °C to +80 °C
Position sensitivity	Less than repeatability error

⁵ Contact Sensirion for information about other gases, wider calibrated temperature ranges and higher storage temperatures.

⁶ For a limited time period.

1.3 Materials

Parameter	SDP600 Series
Wetted materials	PBT (polybutylene terephthalate), glass (silicon nitride, silicon oxide), silicon, gold, FR4, silicone as static sealing, epoxy, copper alloy, lead-free solder
RoHS	The SDP600 series is fully RoHS compliant

2. Electrical Specifications

2.1 Electrical characteristics

Parameter	SDP6x0 / SDP5x0
Operating voltage	3.0– 3.6 Vdc (A stable supply voltage of 3.3 V is recommended)
Current drain	< 6 mA typical in operation (Contact Sensirion for low-power version with minimized sleep mode power drain.)
Interface	Digital 2-wire interface (I ² C)
Bus clock frequency	100 kHz typical, 400 kHz max.
Default I ² C address	64 (binary: 1000 000)
Scale factor ⁵	60 Pa ⁻¹
Scale factor to alternative units ⁶	6'000 mbar ⁻¹ 413'686 psi ⁻¹ 14'945 (inch H ₂ O) ⁻¹

⁵ See section 5.1. The scale factor may vary with other configurations.

⁶ Instead of the standard scale factor (to get the physical value in Pa), the sensor output may be divided by alternative scale factors to receive the physical value in another unit.

3. Interface Specifications

The serial interface of the SDP600 series is optimized in terms of sensor readout and power consumption. It is compatible with I²C interfaces. For detailed specifications of the I²C protocol, see *The I²C Bus Specification*, Version 2.1, January 2000 (source: NXP).

(www.nxp.com/products/interface_control/i2c)

3.1 Interface connection – external components

Bi-directional bus lines are implemented by the devices (master and slave) using open-drain output stages and a pull-up resistor connected to the positive supply voltage.

The recommended pull-up resistor value depends on the system setup (capacitance of the circuit or cable and bus clock frequency). In most cases, 10 kΩ is a reasonable choice.

The capacitive loads on SDA and SCL line have to be the same. It is important to avoid asymmetric capacitive loads.

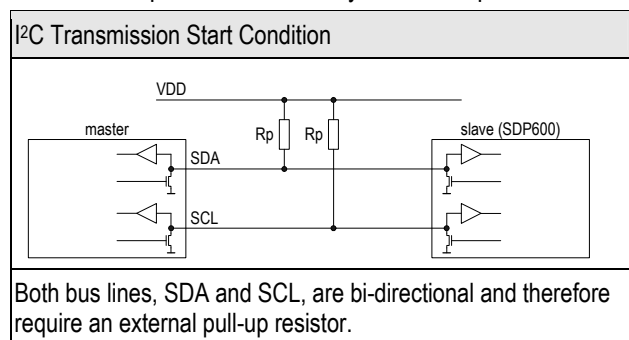

3.2 I²C Address

The I²C address consists of a 7-digit binary value. By default, the I²C address of the SF04 is set to 64 (binary: 1000 000). The address is always followed by a write bit (0) or read bit (1). The default hexadecimal I²C header for read access to the sensor is therefore h81.

3.3 Transfer sequences

Transmission START Condition (S): The START condition is a unique situation on the bus created by the master, indicating to the slaves the beginning of a transmission sequence (the bus is considered busy after a START).

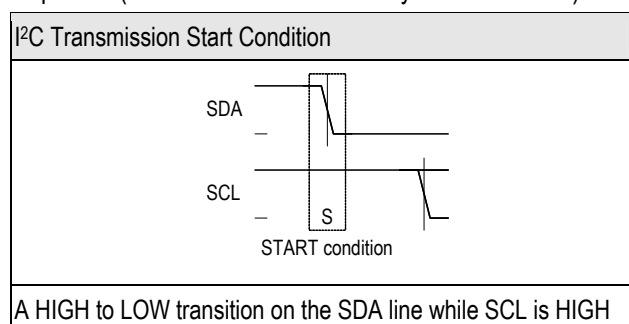

Transmission STOP Condition (P): The STOP condition is a unique situation on the bus created by the master, indicating to the slaves the end of a transmission sequence (the bus is considered free after a STOP).

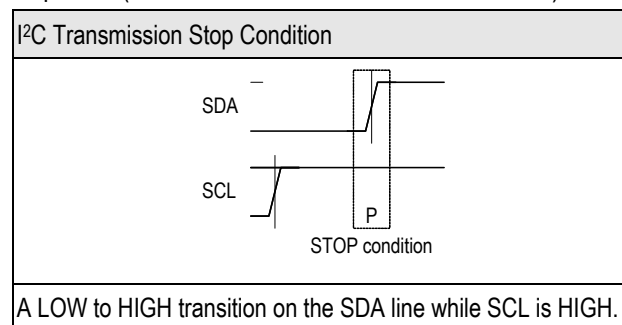

Acknowledge (ACK) / Not Acknowledge (NACK): Each byte (8 bits) transmitted over the I²C bus is followed by an acknowledge condition from the receiver. This means that after the master pulls SCL low to complete the transmission of the 8th bit, SDA will be pulled low by the receiver during the 9th bit time. If after transmission of the 8th bit the receiver does not pull the SDA line low, this is considered to be a NACK condition.

If an ACK is missing during a slave to master transmission, the slave aborts the transmission and goes into idle mode.

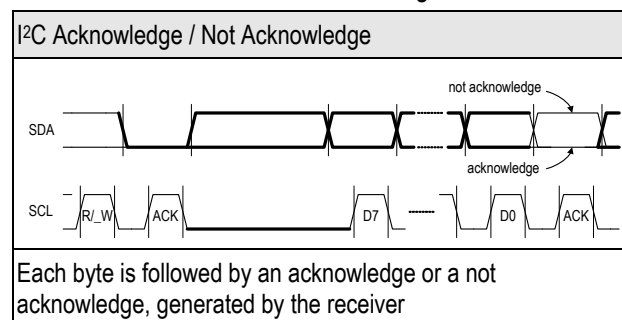

Handshake procedure (Hold Master): In a master-slave system, the master dictates when the slaves will receive or transmit data. However, in some situations a slave device may need time to store received data or prepare data to be transmitted. Therefore, a handshake procedure is required to allow the slave to indicate termination of internal processing.

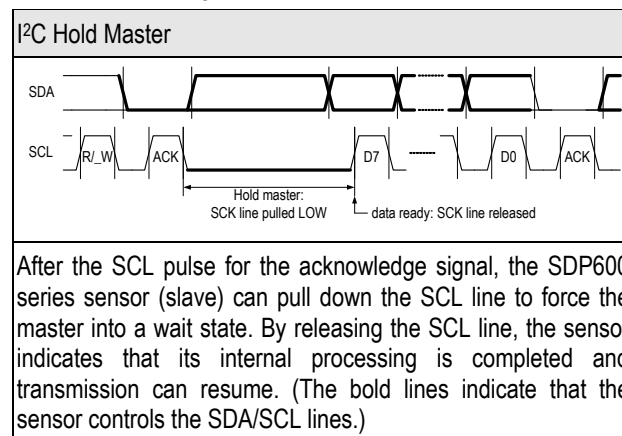

3.4 Data transfer format

Data is transferred in byte packets in the I²C protocol, which means in 8-bit frames. Each byte is followed by an acknowledge bit. Data is transferred with the most significant bit (MSB) first.

A data transfer sequence is initiated by the master generating the Start condition (S) and sending a header byte. The I²C header consists of the 7-bit I²C device address and the data direction bit (R/_W).

The value of the R/_W bit in the header determines the data direction for the rest of the data transfer sequence. If R/_W = 0 (WRITE) the direction remains master-to-slave, while if R/_W = 1 (READ) the direction changes to slave-to-master after the header byte.

4. Command Set and Data Transfer Sequences

A command is represented by an 8-bit command code. The data direction may not change after the command byte, since the R/_W bit of the preceding I²C header has already determined the direction to be master-to-slave. In order to execute commands in Read mode using I²C, the following principle is used. On successful (acknowledged) receipt of a command byte, the sensor stores the command nibble internally. The Read mode of this command is then invoked by initiating an I²C data transfer sequence with R/_W = 1.

If a correctly addressed sensor recognizes a valid command and access to this command is granted, it responds by pulling down the SDA line during the subsequent SCL pulse for the acknowledge signal (ACK). Otherwise it leaves the SDA line unasserted (NACK).

The two most important commands are described in this data sheet, and the data transfer sequences are specified. Contact Sensirion for advanced sensor options.

4.1 Measurement triggering

Each individual measurement is triggered by a separate read operation.

Note that two transfer sequences are needed to perform a measurement. First write command byte hF1 (trigger measurement) to the sensor, and then execute a read operation to trigger the measurement and retrieve the flow or differential pressure information.

On receipt of a header with R/_W=1, the sensor generates the Hold Master condition on the bus until the first measurement is completed (see Section 3.3 for timing). After the Hold Master condition is released, the master can read the result as two consecutive bytes. A CRC byte follows if the master continues clocking the SCL line after

the second result byte. The sensor checks whether the master sends an acknowledge after each byte and aborts the transmission if it does not.

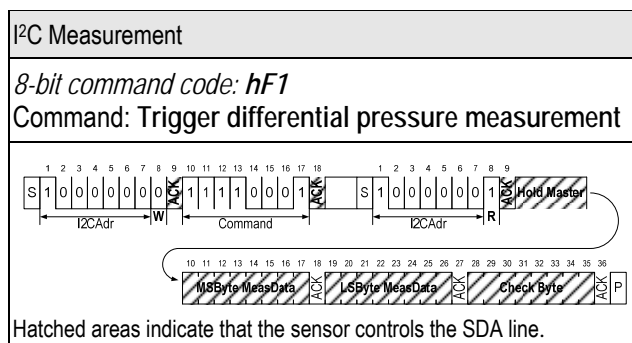

4.2 Soft reset

This command forces a sensor reset without switching the power off and on again. On receipt of this command, the sensor reinitializes the control/status register contents from the EEPROM and starts operating according to these settings.

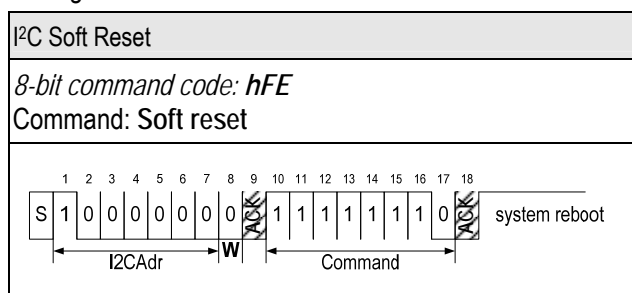

4.3 CRC-8 Redundant Data Transmission

Cyclic redundancy checking (CRC) is a popular technique used for error detection in data transmission. The transmitter appends an n-bit checksum to the actual data sequence. The checksum holds redundant information about the data sequence and allows the receiver to detect transmission errors. The computed checksum can be regarded as the remainder of a polynomial division, where the dividend is the binary polynomial defined by the data sequence and the divisor is a “generator polynomial”.

The SF04 sensor implements the CRC-8 standard based on the generator polynomial

$$x^8 + x^5 + x^4 + 1.$$

Note that CRC protection is only used for data transmitted from the slave to the master.

For details regarding cyclic redundancy checking, please refer to the relevant literature.

5. Conversion to Physical Values

5.1 Signal scaling and physical unit

The calibrated signal read from the sensor is a signed INTEGER number (two's complement number). The INTEGER value can be converted to the physical value by dividing it by the scale factor (pressure = sensor output ÷ scale factor). The scale factor is specified in Section 2.1.

5.2 Temperature compensation

The SDP600 sensor series features digital temperature compensation. The temperature is measured on the CMOSens® chip by an on-chip temperature sensor. This data is fed to a compensation circuit that is also integrated on the CMOSens® sensor chip. No external temperature compensation is necessary.

5.3 Altitude correction

The SDP600 sensor series achieves its unsurpassed performance by using a dynamic measurement principle. The applied differential pressure forces a small flow of gas through the sensor, which is measured by the flow sensor element. As a result, any variation in gas density affects the sensor reading. While temperature effects are compensated internally, variations in atmospheric pressure (elevation above sea level) can be compensated by a correction factor according to the following formula:

$$Dp_{\text{eff}} = Dp_{\text{sensor}} \times (P_{\text{cal}} / P_{\text{amb}})$$

- Dp_{eff} : Effective differential pressure
- Dp_{sensor} : Differential pressure indicated by the sensor
- P_{cal} : Absolute pressure at calibration (966 mbar)
- P_{amb} : Actual ambient absolute pressure.

Altitude correction factors:

Altitude [meters]	Ambient pressure (P_{amb}) [mbar]	Correction factor ($P_{\text{cal}} / P_{\text{amb}}$)
0	1013	0.95
250	984	0.98
425	966	1.00
500	958	1.01
750	925	1.04
1500	842	1.15
2250	766	1.26
3000	697	1.38

Example: At 750 m above sea level and a sensor reading of 40 Pa, the effective differential pressure is 41.8 Pa.

Note: In many HVAC applications such as filter monitoring, fan/ventilation control or air flow measurement, the described effect is actually welcome because the quantity that must effectively be controlled is the mass flow and not the volume flow.

6. OEM Options

A variety of custom options can potentially be implemented for high-volume OEM applications. *None of these options is available with the standard sensors.* Contact Sensirion for more information.

6.1 Switch function

A switch version with a programmable trigger level and programmable hysteresis can be realized.

6.2 Temperature measurement

The sensor temperature can be read out via the digital interface.

6.3 Vdd measurement

The value of the supply voltage Vdd can be read out via the digital interface.

6.4 Minimized power consumption

For low-power applications, the current consumption can be reduced to approximately 3.5 mA.

6.5 Broken sensor element detection

Breakage of the sensor element can be detected by a sensor chip self-test.

6.6 Plausibility checks

An OEM version of the sensor can be configured to provide certain plausibility checks triggered by a microprocessor. This can be used to create a combined sensor/microprocessor system that can be certified as fail-safe.

6.7 Mass flow configuration

A sensor output proportional to mass flow is necessary for measuring mass flow in a bypass configuration. Contact Sensirion for more information about this application.

6.8 Customer-specific interface

For analog voltage output, please contact Sensirion.

7. Mechanical Specifications

7.1 Mechanical concept

The SDP600 Series is designed for through-hole technology and can be wave-soldered or hand-soldered to a PCB.

- The SDP600/SDP500 can be directly connected to a manifold using two O-rings.
- The SDP610/SDP510 has ports for connecting standard-size plastic tubes.

7.2 Mechanical characteristics

Parameter	SDP510/SDP610	SDP500/SDP600
PCB attachment	Clip-in and hand or wave soldering. Additional mechanical attachment depending on force requirements	
Allowable overpressure	1 bar (100 kPa, 400 inches H ₂ O)	
Rated burst pressure	> 5 bar	
Gas flow through sensor	< 150 ml/min	
Weight	< 6 g	
Protection rating	IP 30	

7.3 SDP600/SDP500 – Manifold connection

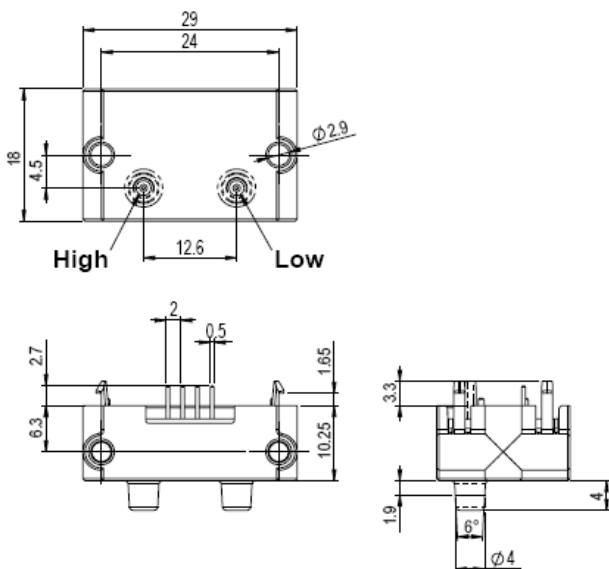

Figure 1: SDP600/SDP500 manifold mount version. All dimensions are in mm.

Sensirion recommends O-rings with the following dimensions:

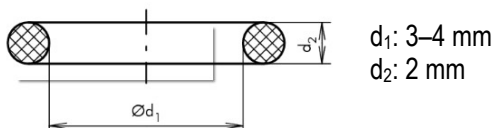

Figure 2: Cross section of recommended O-ring

7.4 SDP610/SDP510 – Tube connection

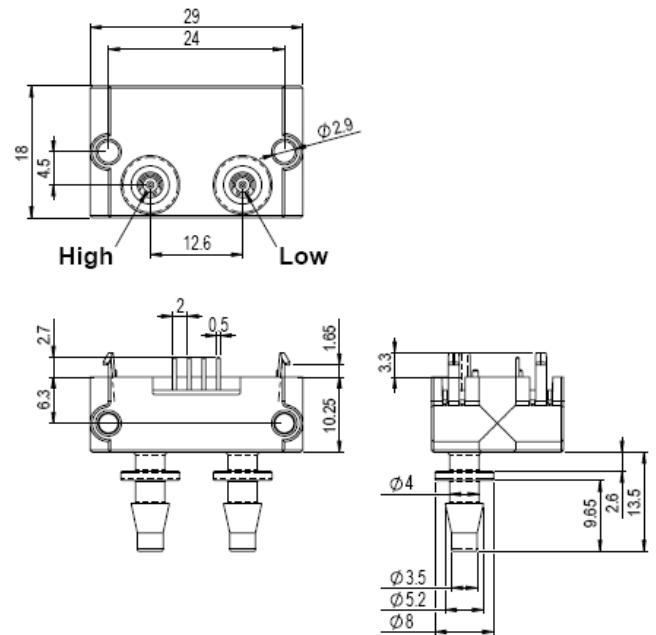
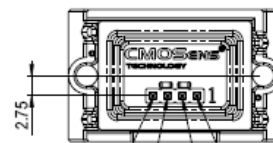

Figure 3: SDP610/SDP510 version with ports for tube connection. All dimensions are in mm.

7.5 Pin assignments



Data GND VDD Clock

Figure 4: Digital output pin assignments (bottom view).

7.6 Footprint

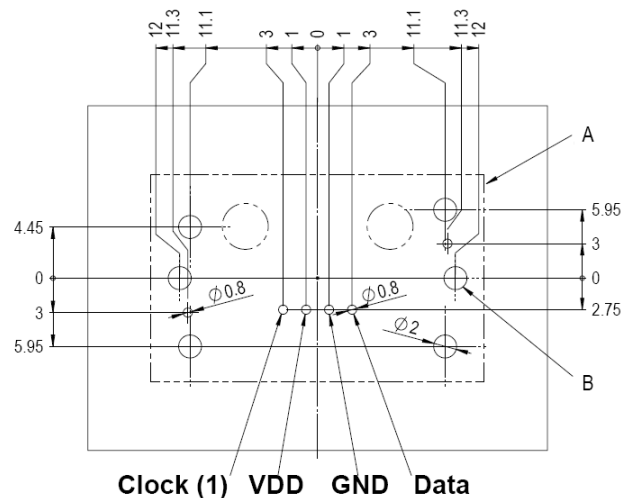

Figure 5: Footprint for PCB mounting. (top view = sensor side). All dimensions in mm.

A: Overall sensor dimensions

B: Holes for additional mounting screws (optional)

8. Instructions for Use

8.1 Soldering instructions

Standard wave soldering systems may be used for soldering SDP600 series sensors. Reflow soldering is not feasible and may damage the sensor.

The sensor ports must be protected from solder splash and flux during soldering. Figure 6 shows an appropriate temperature profile with maximum temperature values.

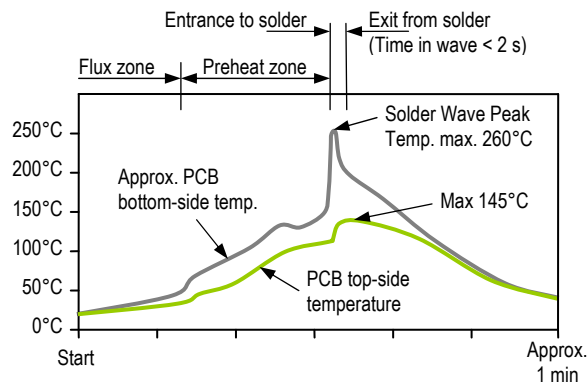

Figure 6: Suitable wave soldering profile.

The characteristics of wave soldering machines vary, so any soldering setup must be tested before production use.

8.2 Sensor handling

The sensors of the SDP600 series are designed to be robust and vibration resistant. Nevertheless, the accuracy of the high-precision SDP600 series can be degraded by rough handling. Sensirion does not guarantee proper operation in case of improper handling. Note: avoid applying any mechanical stress to the solder joints of the sensor during or as a result of PCB assembly.

The sensor ships in an antistatic package to prevent electrostatic discharge (ESD), which can damage the part. To avoid such damage, ground yourself using a grounding strap or by touching a grounded object. Furthermore store the parts in the antistatic package when not in use.

8.3 Additional attachment

If necessary, the robustness of the sensor attachment to the PCB can be increased by using a bracket as shown in Figure 7.

Sensirion recommends using this additional bracket when the sensor is fitted to a PCB. The bracket must be secured before the pins are soldered to the PCB, as otherwise sensor performance may be degraded by mechanical stress.

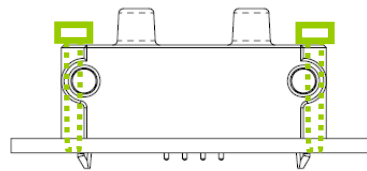

Figure 7: Supplementary bracket for the SDP600 series.

8.4 Air flow and tubing

Due to the dynamic measurement principle, a small air flow is required.

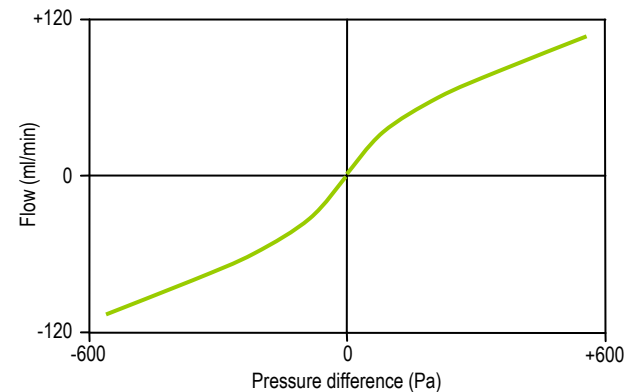

Figure 8: Typical air flow through the SDP6x0.

Note: 1 sccm = 1 cm³/min at 0°C and 1013 mbar
(1 sccm = 0.001 standard liter).

This air flow through the sensor creates a dependence on the tube length. The error is less than 1% with a tube length up to 1 m (with 3/16 inch inside diameter).

9. Ordering Information

Use the part names and item numbers shown in the following table when ordering SDP600 series differential pressure sensors. For the latest product information and local distributors, visit www.sensirion.com.

Part name	Description / Output	Calibrated range	Span accuracy	Item number
SDP500	I ² C, manifold mount	0 to +500 Pa (0 to +2 in. H ₂ O)	4.5%	1-100601-01
SDP510	I ² C, tube connection	0 to +500 Pa (0 to +2 in. H ₂ O)	4.5%	1-100602-01
SDP600	I ² C, manifold mount	0 to ±500 Pa (0 to ±2 in. H ₂ O)	3%	1-100456-01
SDP610	I ² C, tube connection	0 to ±500 Pa (0 to ±2 in. H ₂ O)	3%	1-100455-01
SDP7xx	Customer specific			n/a

Packaging units: 80 items/tray and 480 items/box.

9.1 Packaging

Housing: The sensor housing consists of PBT. The device is fully RoHS compliant – it is free of Pb, Cd, Hg, Cr(6+), PBB and PBDE.

Each sensor is labeled by laser printing on the front side:

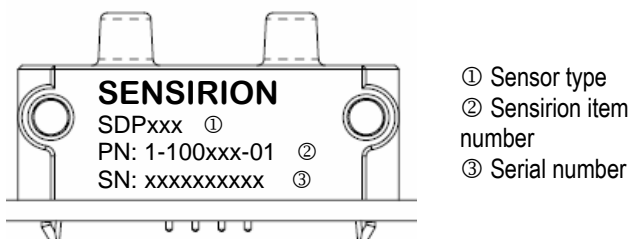

Figure 9: Marking of the housing.

Traceability Information: SDPxxx are shipped in trays of 80pcs. The tray dimension is 355mm x 255mm x 21.5mm. By piling them up, the height per tray can be considered as 19mm. For traceability, each tray is marked with a label. No information can be derived from the code directly, respective data is stored at Sensirion AG and is provided upon request.

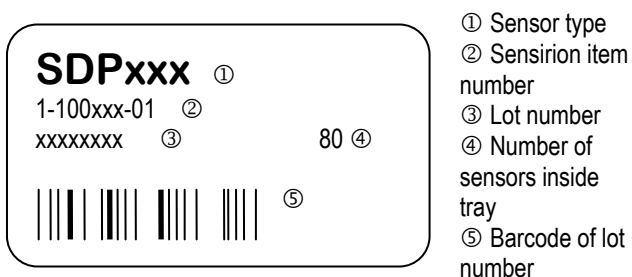

Figure 10: Label sticking on each tray

10. Revision history

Date	Version	Changes
Sept. 20, 2008	V1.0	Initial release
Nov. 9, 2008	V1.1	Small amendments (power consumption, asymmetric lines and US office address)
Jan, 2009	V1.2	Explanation to SDP5x0 calibration range, media compatibility extended
Feb, 2009	V1.3	Packaging information added, sensor handling instruction
Nov, 2009	V1.4	Zero point accuracy specified 0.2 Pa instead of 0.5 Pa. Supply voltage requirements and recommendations relaxed. Various small amendments.

Important Notices

Warning, personal injury

Do not use this product as safety or emergency stop devices or in any other application where failure of the product could result in personal injury (including death). Do not use this product for applications other than its intended and authorized use. Before installing, handling, using or servicing this product, please consult the datasheet and application notes. Failure to comply with these instructions could result in death or serious injury.

If the Buyer shall purchase or use SENSIRION products for any unintended or unauthorized application, Buyer shall defend, indemnify and hold harmless SENSIRION and its officers, employees, subsidiaries, affiliates and distributors against all claims, costs, damages and expenses, and reasonable attorney fees arising out of, directly or indirectly, any claim of personal injury or death associated with such unintended or unauthorized use, even if SENSIRION shall be allegedly negligent with respect to the design or the manufacture of the product.

ESD Precautions

The inherent design of this component causes it to be sensitive to electrostatic discharge (ESD). To prevent ESD-induced damage and/or degradation, take customary and statutory ESD precautions when handling this product.

See application note "Handling Instructions" for more information.

Warranty

SENSIRION warrants solely to the original purchaser of this product for a period of 12 months (one year) from the date of delivery that this product shall be of the quality, material and workmanship defined in SENSIRION's published specifications of the product. Within such period, if proven to be defective, SENSIRION shall repair and/or replace this product, in SENSIRION's discretion, free of charge to the Buyer, provided that:

- notice in writing describing the defects shall be given to SENSIRION within fourteen (14) days after their appearance;
- such defects shall be found, to SENSIRION's reasonable satisfaction, to have arisen from SENSIRION's faulty design, material, or workmanship;
- the defective product shall be returned to SENSIRION's factory at the Buyer's expense; and
- the warranty period for any repaired or replaced product shall be limited to the unexpired portion of the original period.

This warranty does not apply to any equipment which has not been installed and used within the specifications recommended by SENSIRION for the intended and proper use of the equipment. EXCEPT FOR THE WARRANTIES EXPRESSLY SET FORTH HEREIN, SENSIRION MAKES NO WARRANTIES, EITHER EXPRESS OR IMPLIED, WITH RESPECT TO THE PRODUCT. ANY AND ALL WARRANTIES, INCLUDING WITHOUT LIMITATION, WARRANTIES OF MERCHANTABILITY OR FITNESS FOR A PARTICULAR PURPOSE, ARE EXPRESSLY EXCLUDED AND DECLINED.

SENSIRION is only liable for defects of this product arising under the conditions of operation provided for in the datasheet and proper use of the goods. SENSIRION explicitly disclaims all warranties, express or implied, for any period during which the goods are operated or stored not in accordance with the technical specifications.

SENSIRION does not assume any liability arising out of any application or use of any product or circuit and specifically disclaims any and all liability, including without limitation consequential or incidental damages. All operating parameters, including without limitation recommended parameters, must be validated for each customer's applications by customer's technical experts. Recommended parameters can and do vary in different applications.

SENSIRION reserves the right, without further notice, (i) to change the product specifications and/or the information in this document and (ii) to improve reliability, functions and design of this product.

Copyright © 2001-2009, SENSIRION.
CMOSens® is a trademark of Sensirion
All rights reserved

RoHS and WEEE Statement

The SDP600 Series complies with requirements of the following directives:

- EU Directive 2002/96/EC on waste electrical and electronic equipment (WEEE), OJ13.02.2003; esp. its Article 6 (1) with Annex II.
- EU Directive 2002/95/EC on the restriction of the use of certain hazardous substances in electrical and electronic equipment (RoHS), OJ 13.02.2003; esp. its Article 4.



Headquarter and Sales Offices

SENSIRION AG
Laubisruetistr. 50
CH-8712 Staefa ZH
Switzerland

Phone: + 41 (0)44 306 40 00
Fax: + 41 (0)44 306 40 30
info@sensirion.com
www.sensirion.com

SENSIRION Korea Co. Ltd.
#1414, Anyang Construction Tower B/D,
1112-1, Bisan-dong, Anyang-city,
Gyeonggi-Province, South Korea

Phone: +82-31-440-9925~27
Fax: +82-31-440-9927
info@sensirion.co.kr
www.sensirion.co.kr

SENSIRION Inc
Westlake Pl. Ctr. I, suite 204
2801 Townsgate Road
Westlake Village, CA 91361
USA

Phone: +1 805-409 4900
Fax: +1 805-435 0467
michael.karst@sensirion.com
www.sensirion.com

SENSIRION China Co. Ltd.
Room 2411, Main Tower
Jin Zhong Huan Business Building,
Postal Code 518048
Futian District, Shenzhen, PR China

Phone: +86 755 8252 1501
Fax: +86 755 8252 1580
info@sensirion.com.cn
www.sensirion.com.cn

SENSIRION Japan
Sensirion Japan Co. Ltd.
Shinagawa Station Bldg. 7F
4-23-5 Takanawa
Minato-ku, Tokyo, Japan

phone: +81 3-3444-4940
fax: +81 3-3444-4939
info@sensirion.co.jp
www.sensirion.co.jp

Find your local representative at: <http://www.sensirion.com/rep>